

Hoshizaki America, Inc.

Modular Cuber

Model
IM-500SAA



“A Superior Degree
of Reliability”

www.hoshizaki.com

PARTS LIST



Number: M029-3750
Issued: 10-02-2012
Revised: 12-17-2013

Auxiliary Codes

IM-500SAA	B-1	October 2012
	B-2	December 2012
	C-0	January 2013
	C-1	February 2013

AUXILIARY CODE

The auxiliary code is the first two characters in the serial number. The first character indicates the year. Years progress or regress in alphabetical order. The series runs from "A" through "V" and the letters "I" and "O" are skipped. The second character indicates significant part changes within a year. Base is "0" and this number advances for each change. In cases where there is a letter in parentheses, this designates the month. This is the last character in the serial number. The series runs from "(A)" through "(M)" and the letter "(I)" is skipped. This designation is only included when identifying a parts change within an auxiliary code.

Note About Ordering Parts

Most assemblies cannot be ordered as complete units; parts in the assemblies generally must be ordered separately.

MARKS LOCATED UNDER THE AUXILIARY CODE

- = Part deleted.
- x = Part deleted and replaced by "o" part.
- o = New part in place of "x" part.

FASTENER PART NUMBER

SCREWS

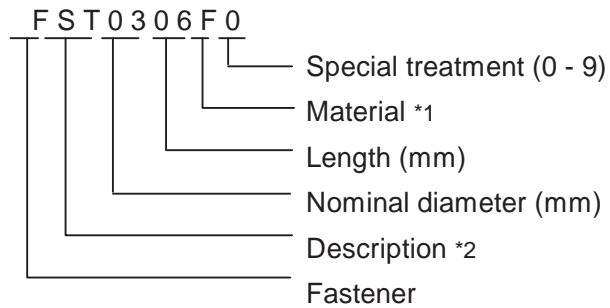

*1 Material

- F: Steel
- S: Austenitic stainless steel
- M: Martensitic stainless steel
- B: Copper alloy
- P: Polycarbonate
- N: Polyamide
- V: PVC
- A: ABS
- X: Polyacetal
- L: Aluminum

NUTS & WASHERS

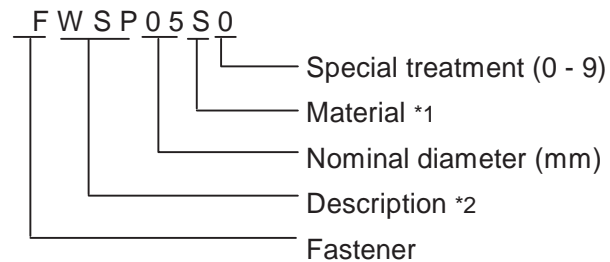

*2 Description

- First letter
- S: Machine screw
- T: Tapping screw
- M: Wood screw
- B: Bolt
- W: Washer
- N: Nut

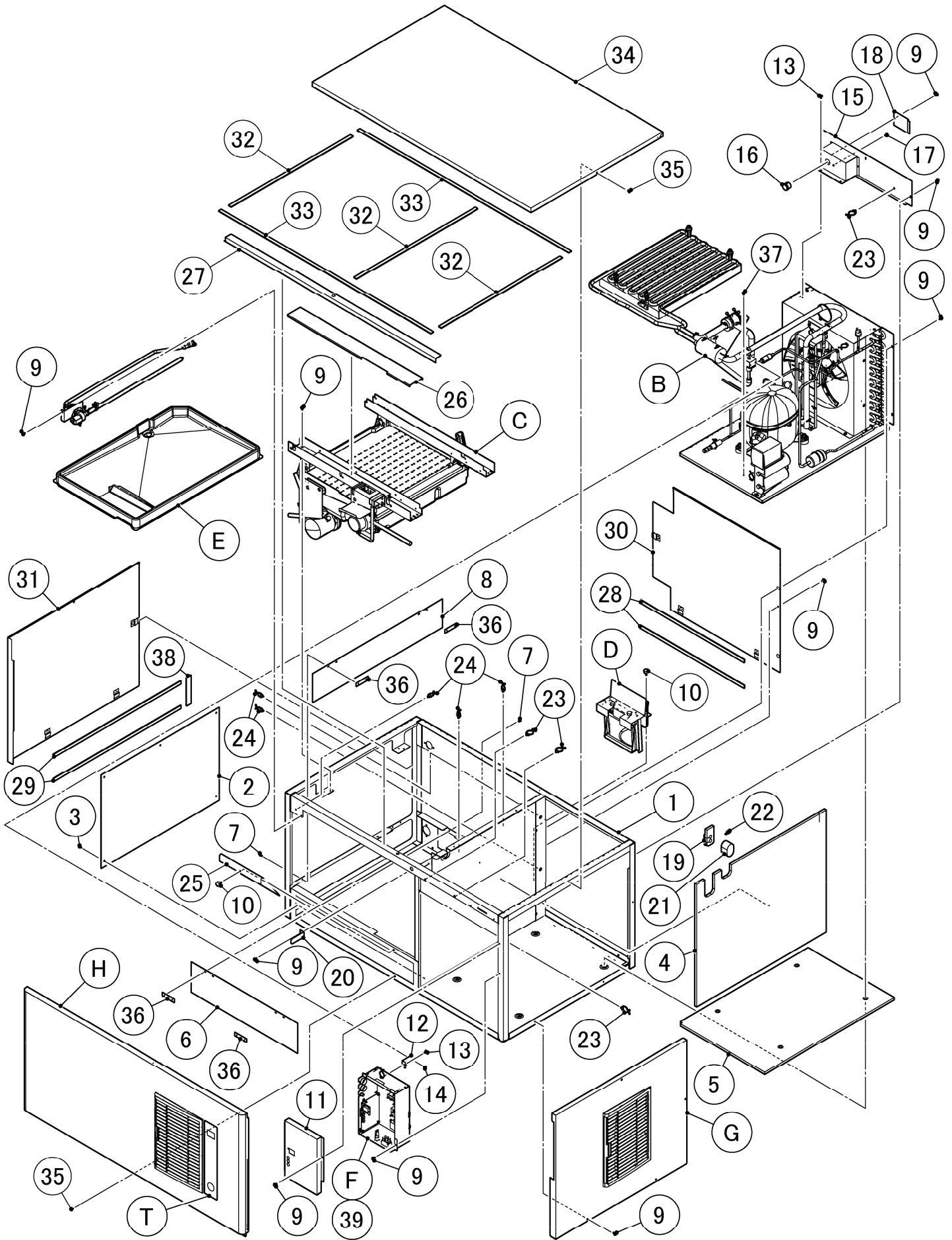

HA

MODEL: IM-500SAA		TITLE: A. ICE CUBER ASSY					
INDEX NO.	DESCRIPTION	MATERIAL OR MODEL NUMBER	PART NUMBER	REQ'D NUMBER			
				B-1	B-2 C-0	C-1	
B	REFRIGERATION ASSY		121598A01	1	1	1	
C	MECHANISM ASSY		121611A01	1	1	1	
D	BIN SW ASSY		376240A01	1	1	1	
E	WATER CIRCUIT ASSY		261583A01	1	1	1	
F	CONTROL BOX ASSY		261953A01	1	1	1	
G	SIDE PANEL(R)		376049A01	1	1	1	
H	FRONT COVER		261961A01	1	1	1	
S	LABEL LOCATION		261629A01	1	1	1	
T	ACCESSORIES		A02669-01	1	1	1	
1	UNIT FRAME		121607G01	1	1	1	
2	PROTECTOR - SEPARATOR		376012P01	1	1	1	
3	T2 TRUSS HEAD SCREW		FT20408S0	5	5	5	
4	INSULATION-SEPARATOR		376005P01	1	1	1	
5	INSULATION-CHASSIS		476401P01	1	1	1	
6	SHIELD(A1)		377294P01	1	1	1	
7	RIVET	SSD43SSBS(t3.2~4.8)	7170-0005	8	8	8	
8	SHIELD(B1)		377296P01	1	1	1	
9	FLANGE BOLT(C-TITE)		FTR0408M0	24	24	24	
10	THUMBSCREW		415949G10	3	3	3	
11	CONTROL BOX COVER		376269M01	1	1	1	
12	BRACKET - HV		476433M01	1	1	1	
13	T2 TRUSS HEAD SCREW		FT20408F0	3	3	3	
14	TRUSS HEAD SCREW		FST0408F0	2	2	2	
15	REAR PANEL(R)		376276G01	1	1	1	
16	BUSHING		420472-05	1	1	1	
17	SCREW - GROUNDING		433304-02	1	1	1	

HA

MODEL: IM-500SAA		TITLE: A. ICE CUBER ASSY					
INDEX NO.	DESCRIPTION	MATERIAL OR MODEL NUMBER	PART NUMBER	REQ'D NUMBER			
				B-1	B-2 C-0	C-1	
18	JUNCTION BOX COVER		433410-01	1	1	1	
19	GROMMET		476434R01	1	1	1	
20	BRACKET-GROMMET		476435M01	1	1	1	
21	INSULATION TUBE		H71020200	1	1	1	
22	NYLON TIE	CV-200	7920-0010	1	1	1	
23	CLAMP	No.2674	427902-02	4	4	4	
24	CLAMP	No.249	427902-03	5	5	5	
25	ICE GUIDE		476685M01	1	1	1	
26	GUIDE-CONNECTOR		312762-01	1	1	1	
27	HOOK-TOP PANEL		376045M01	1	1	-	
28	GASKET	4A0808L02	121622Z01	2	2	2	
29	GASKET	4A0808L02	121622Z02	2	2	2	
30	REAR PANEL(A)		376046G01	1	1	1	
31	SIDE PANEL(L)		376048G01	1	1	1	
32	GASKET	4A0808L02	121622Z03	3	3	3	
33	GASKET	4A0808L02	121622Z04	2	2	2	
34	TOP PANEL		121771M01	1	1	-	
			122779M01	-	-	1	
35	S-TITE TRUSS HEAD SCREW		FTS0408M0	3	3	3	
36	PLATE-SHIELD		477674M01	4	4	4	
37	HEX HEAD BOLT (SPRING WASHER AND FLAT WASHER)		FBK0408S0	1	1	1	
38	GASKET	4A0808L02	121622Z05	1	1	1	
39	WIRE HARNESS		261627S--	1	-	-	
			264542S--	-	1	1	

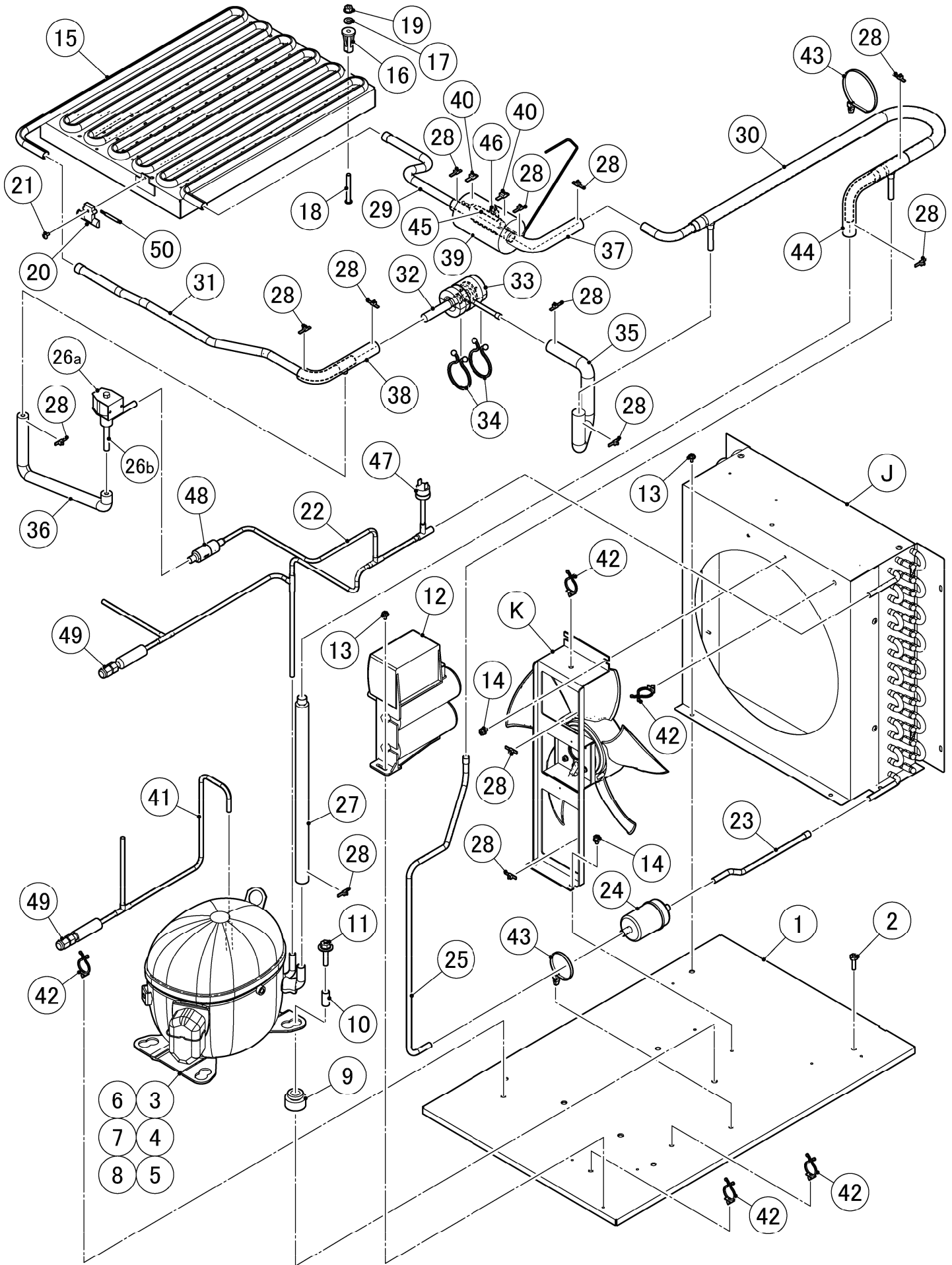

HA

MODEL: IM-500SAA							
TITLE: B. REFRIGERATION ASSY							
INDEX NO.	DESCRIPTION	MATERIAL OR MODEL NUMBER	PART NUMBER	REQ'D NUMBER			
				B-1	B-2 C-0	C-1	
J	COND. ASSY		375980A01	1	1	1	
K	FAN MOTOR ASSY		375981A01	1	1	1	
1	BASE		375979G01	1	1	1	
2	HEX HEAD BOLT		FBH0620S0	4	4	4	
3	COMPRESSOR		P02510-01	1	1	1	
4	TERMINAL COVER	NT6222GKV etc. ACCESSORIES	P02863-01	1	1	1	
5	SPRING	NT6222GKV etc. ACCESSORIES	P02578-01	1	1	1	
6	PROTECTOR	NT6222GKV etc. ACCESSORIES	P02512-01	1	1	1	
7	PROTECTOR GASKET	NT6222GKV etc. ACCESSORIES	P02580-01	1	1	1	
8	SCREW	NT6222GKV etc. ACCESSORIES	P00840-01	1	1	1	
9	GROMMET	NT6222GKV etc. ACCESSORIES	P00846-01	4	4	4	
10	SPACER	NT6222GKV etc. ACCESSORIES	P00847-01	4	4	4	
11	BOLT		436206-03	4	4	4	
12	ELECTRICAL COMPONENTS	NT6222GKV etc. ACCESSORIES	P02511-01	1	1	1	
13	FLANGE BOLT(C-TITE)		FTR0408M0	5	5	5	
14	HEX HEAD BOLT (SPRING WASHER AND FLAT WASHER)		FBK0508F0	4	4	4	
15	EVAPORATOR		2H7526G02	1	1	1	
16	COLLAR		3H3879-01	4	4	4	
17	WASHER		4H0777-01	4	4	4	
18	SCREW EVAPORATOR		4Y4922M02	4	4	4	
19	FLANGE NUT		FNHF06S0	4	4	4	
20	HOLDER - THERMISTOR		3H9642-01	1	1	1	
21	S-TITE TRUSS HEAD SCREW		FTS0408M0	1	1	1	
22	COPPER TUBE(A)-HIGH SIDE		261879G01	1	1	1	
23	COPPER TUBE(B)-HIGH SIDE		476553M01	1	1	1	

HA

MODEL: IM-500SAA							
TITLE: B. REFRIGERATION ASSY							
INDEX NO.	DESCRIPTION	MATERIAL OR MODEL NUMBER	PART NUMBER	REQ'D NUMBER			
				B-1	B-2 C-0	C-1	
24	DRIER	DML032.5s	462965-01	1	1	1	
25	COPPER TUBE(C)-HIDH SIDE		376210M01	1	1	1	
26a	VALVE COIL	ATS-C12HDU-3	4A3277-01	1	1	1	
26b	VALVE BODY	ATS-B7SHDU-1	4A3276-01	1	1	1	
27	COPPER TUBE(A)-LOW SIDE		476554G01	1	1	1	
28	TIE	CV-150	7920-0003	13	13	13	
29	COPPER TUBE(B)-LOW SIDE		476556M01	1	1	1	
30	HEAT EXCHANGER		376258G01	1	1	1	
31	COPPER TUBE(C)-LOW SIDE		376212G01	1	1	1	
32	EXPANSION VALVE	HFE-10NHD-1	453008-01	1	1	1	
33	VALVE COVER		3Y3196P01	1	1	1	
34	CLAMP		P00752-01	2	2	2	
35	COPPER TUBE(D)-HIGH SIDE		476558G01	1	1	1	
36	COPPER TUBE (A) - HOT GAS		375987G01	1	1	1	
37	INSULATION TUBE		H71020600	1	1	1	
38	INSULATION TUBE		H71020300	1	1	1	
39	INSULATION TUBE		H73858100	1	1	1	
40	NYLON TIE	CV-200	7920-0010	2	2	2	
41	COPPER TUBE (A) - PROCESS		375988G01	1	1	1	
42	CLAMP	No.2674	427902-02	5	5	5	
43	TIE		436156-02	2	2	2	
44	INSULATION TUBE	7762-1020	H71020400	1	1	1	
45	HOLDER - EXP. VALVE 1/2		3A0112-01	1	1	1	
46	CLAMP		443461-01	1	1	1	
47	PRESSURE SWITCH	(Included in item 22 : 261879G01) ACB -1VB44	463180-04	1	1	1	
48	STRAINER	(Included in item 22 : 261879G01)	P00812-01	1	1	1	
49	ACCESS VALVE	(Included in item 22 and 41: 261879G01, 375988G01) TCJ-2F20NHDU-1	457729-01	2	2	2	
50	THERMISTOR - CUBE CONTROL		P00350-01	1	1	1	

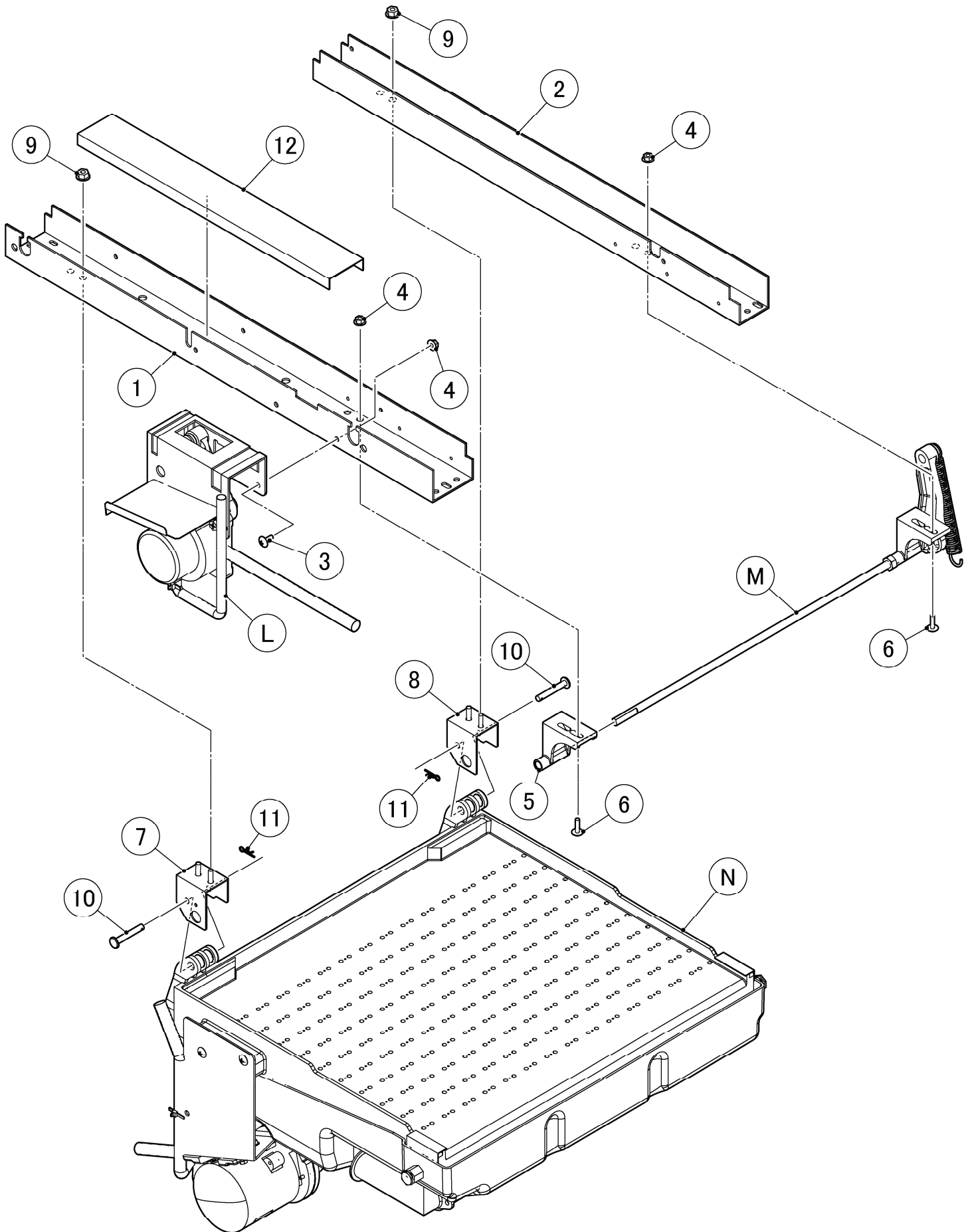

HA

MODEL: IM-500SAA		TITLE: C. MECHANISM ASSY					
INDEX NO.	DESCRIPTION	MATERIAL OR MODEL NUMBER	PART NUMBER	REQ'D NUMBER			
				B-1	B-2 C-0	C-1	
L	ACTUATOR MOTOR ASSY		376007A01	1	1	1	
M	CAM SHAFT ASSY		3Y5364A02	1	1	1	
N	WATER PAN ASSY		121613A01	1	1	1	
1	FRONT FRAME		3Y5020M01	1	1	1	
2	REAR FRAME		3Y5021M01	1	1	1	
3	TRUSS HEAD MACHINE SCREW		FST0512S0	2	2	2	
4	FLANGE NUT		FNHF05S0	6	6	6	
5	BEARING-CAM SHAFT		3X8307-02	1	1	1	
6	TRUSS HEAD SCREW		FST0516S0	4	4	4	
7	BEARING PLATE		3H1440G03	1	1	1	
8	BEARING PLATE		3H1440G04	1	1	1	
9	FLANGE NUT		FNHF06S0	4	4	4	
10	SHAFT (B)		4H1184-02	2	2	2	
11	SNAP PIN		715S-0006	2	2	2	
12	GUIDE-CONNECTOR		4H5619-01	1	1	1	

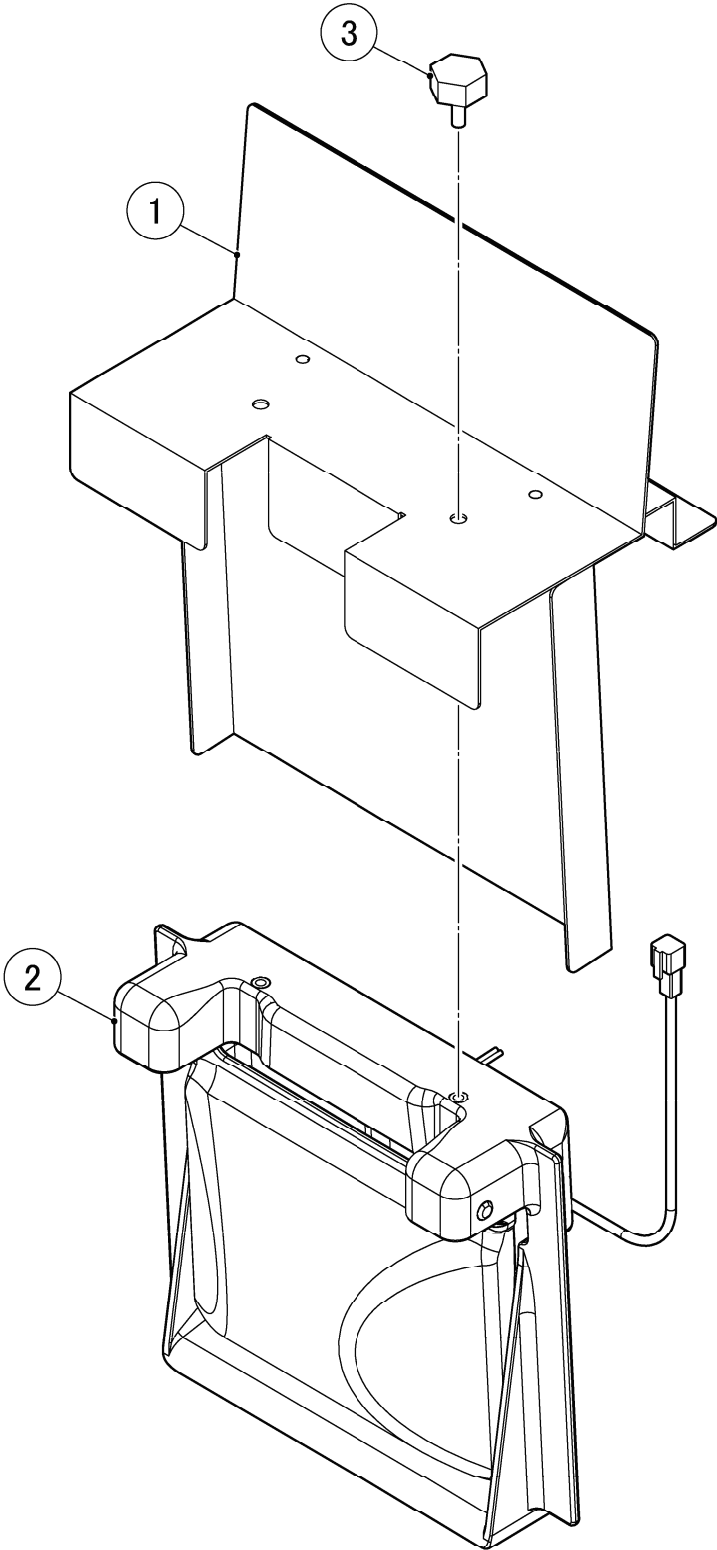

HA

MODEL: IM-500SAA		TITLE: D. BIN SW ASSY					
INDEX NO.	DESCRIPTION	MATERIAL OR MODEL NUMBER	PART NUMBER	REQ'D NUMBER			
				B-1	B-2 C-0	C-1	
1	SWITCH MOUNT		476570G01	1	1	1	
2	BIN CONTROL		2A4393G01	1	1	1	
3	THUMBSCREW		415949G10	2	2	2	

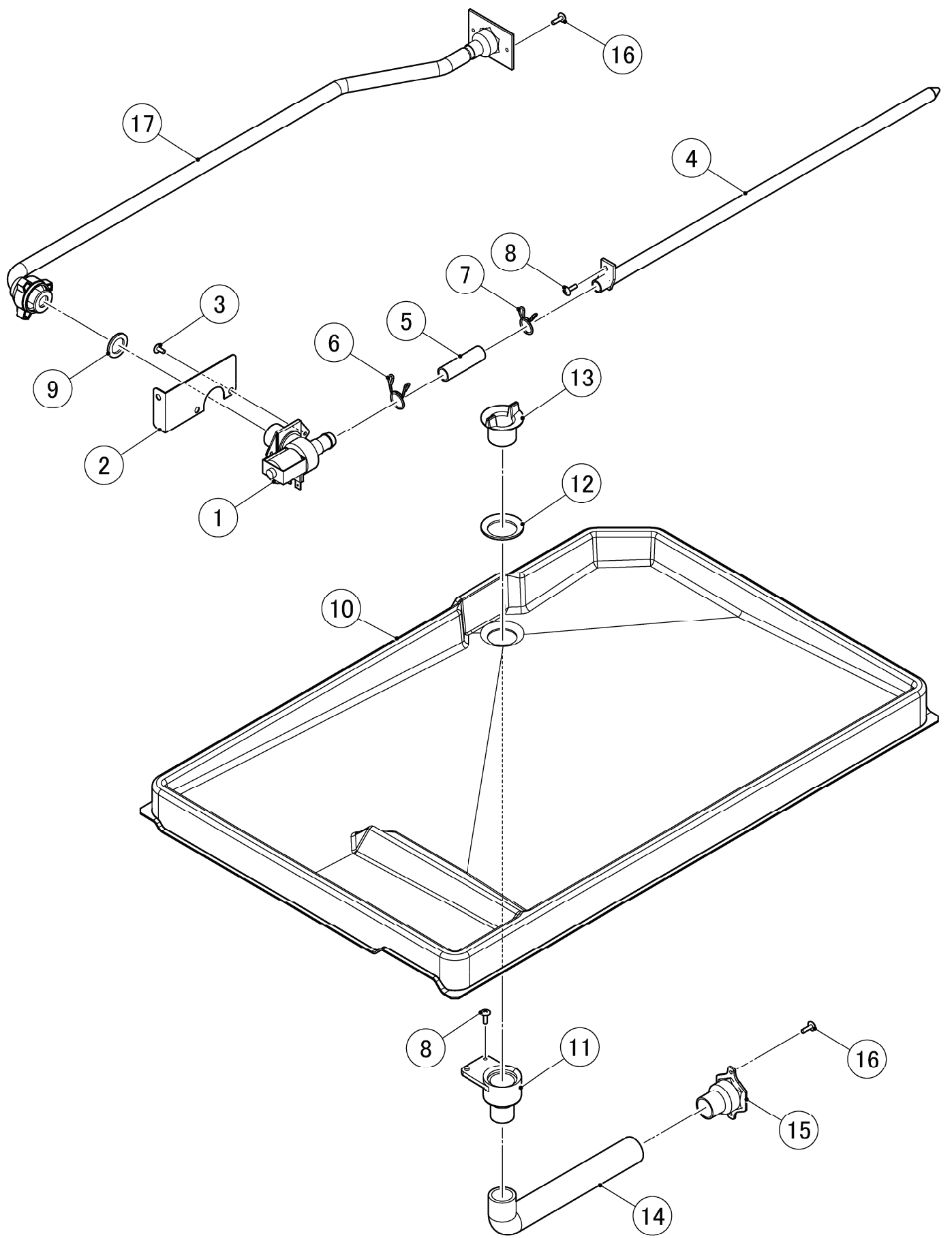

HA

MODEL: IM-500SAA				TITLE: E. WATER CIRCUIT ASSY			
INDEX NO.	DESCRIPTION	MATERIAL OR MODEL NUMBER	PART NUMBER	REQ'D NUMBER			
				B-1	B-2 C-0	C-1	
1	WATER VALVE	V19	P01559-01	1	1	1	
2	BRACKET - WV		476431M01	1	1	1	
3	TRUSS HEAD SCREW		FST0408S0	2	2	2	
4	WATER SUPPLY PIPE		376015G01	1	1	1	
5	SILICONE HOSE-WHITE		H21014050	1	1	1	
6	HOSE CLAMP	SK-15	435934-03	1	1	1	
7	HOSE CLAMP	SK-14	435934-02	1	1	1	
8	TRUSS HEAD SCREW		FST0412S0	2	2	2	
9	RUBBER GASKET		413854-03	1	1	1	
10	DRAIN PAN		208186-01	1	1	1	
11	DRAIN PIPE		376019P01	1	1	1	
12	PACKING		413857-01	1	1	1	
13	DRAIN YOKE		418296-01	1	1	1	
14	HOSE (B)		436599-01	1	1	1	
15	DRAIN FITTING		477775G01	1	1	1	
16	T2 TRUSS HEAD SCREW		FT20412S0	4	4	4	
17	WATER SUPPLY PIPE		379198G01	1	1	1	

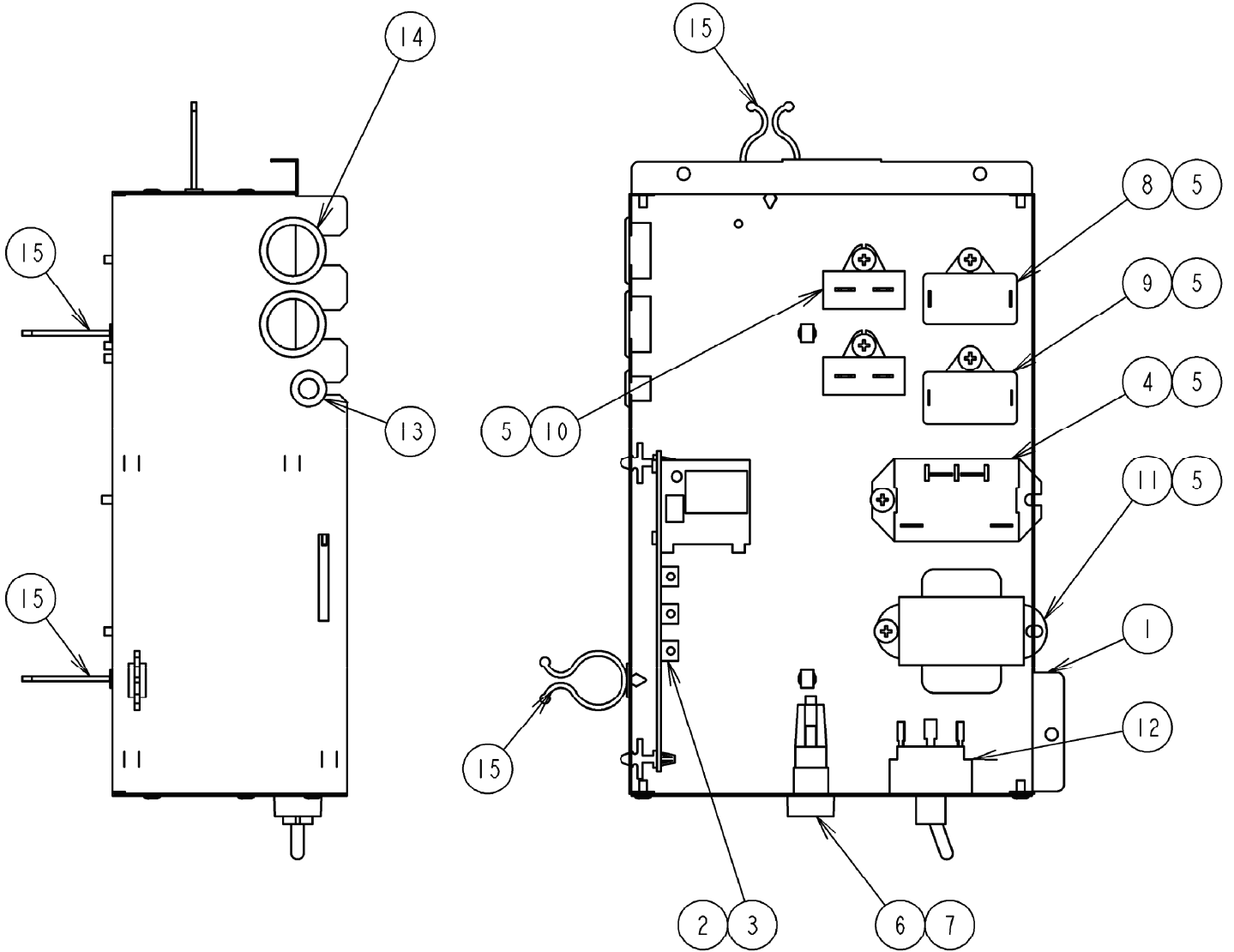

HA

MODEL: IM-500SAA				TITLE: F. CONTROL BOX ASSY			
INDEX NO.	DESCRIPTION	MATERIAL OR MODEL NUMBER	PART NUMBER	REQ'D NUMBER			
				B-1	B-2 C-0	C-1	
1	CONTROL BOX(A)		376268G01	1	1	1	
2	BOARD SUPPORT	KGLS-4S	414929-02	4	4	4	
3	CONTROLLER BOARD		P01873-01	1	1	1	
4	POWER RELAY	G7L-1A-TUB	449000-01	1	1	1	
5	T2 TRUSS HEAD SCREW		FT20408F0	6	5	5	
6	FUSE HOLDER	BF115	P00014-01	1	1	1	
7	FUSE	FGAO-2	420468-02	1	1	1	
8	FAN MOTOR CAPACITOR	FUJ22B605UEF 6.0MFD, 220VAC	443158-02	1	1	1	
9	PUMP MOTOR CAPACITOR	VP25B555UEF 5.5MFD, 250VAC	443192-03	1	1	1	
10	ACTUATOR MOTOR CAPACITOR	SH-JPX 0.8MFD, 250VAC	416969-01	2	1	1	
11	TRANSFORMER		3A4395-01	1	1	1	
12	TOGGLE SWTICH	KND203	P00033-01	1	1	1	
13	BUSHING	OCB-500	428394-02	1	1	1	
14	BUSHING	OCB-1000	428394-05	2	2	2	
15	CLAMP	No.2674	427902-02	4	4	4	

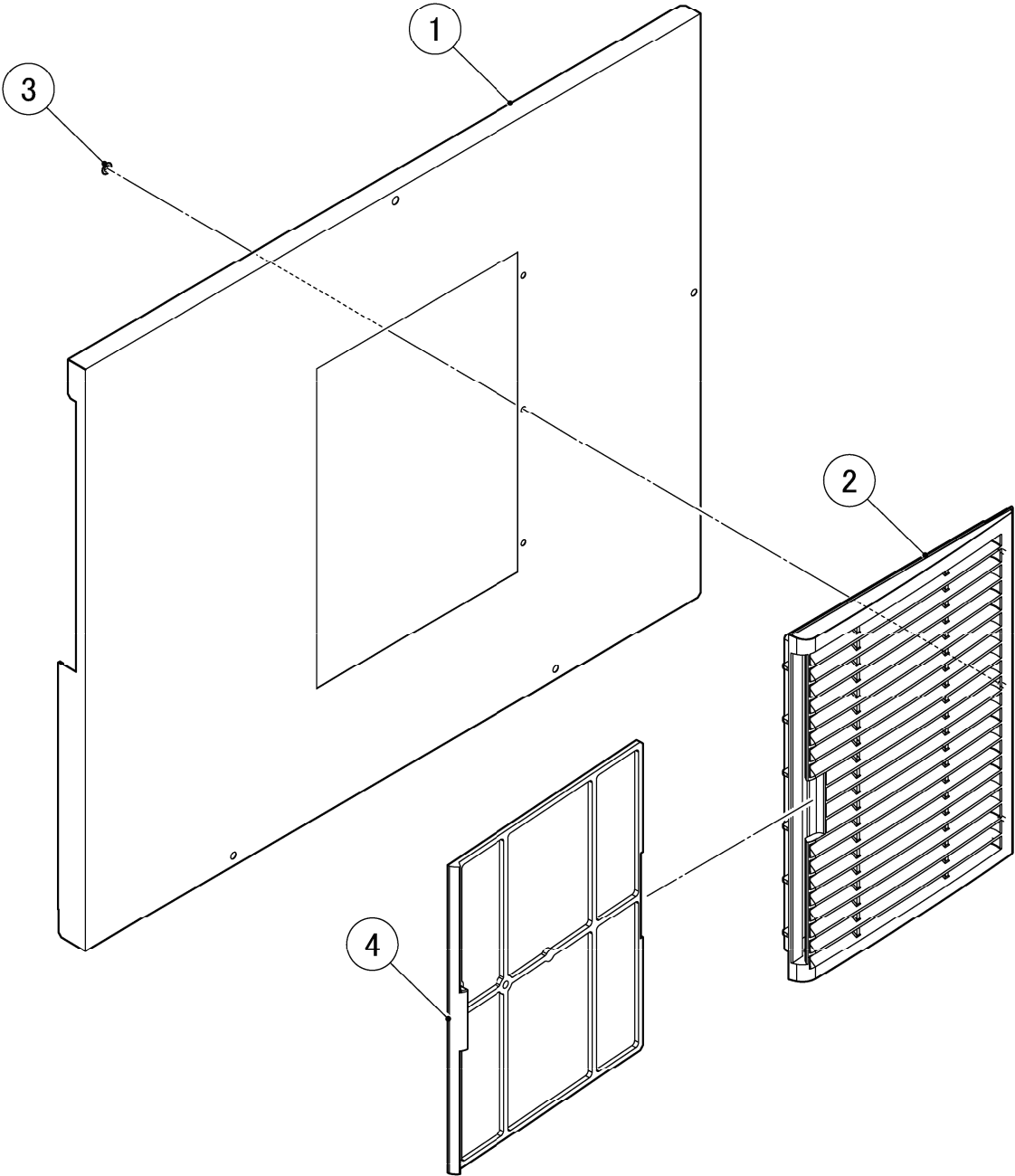

HA

MODEL: IM-500SAA		TITLE: G. SIDE PANEL(R)					
INDEX NO.	DESCRIPTION	MATERIAL OR MODEL NUMBER	PART NUMBER	REQ'D NUMBER			
				B-1	B-2 C-0	C-1	
1	SIDE PANEL(R1)		261595M01	1	1	1	
2	LOUVER (B)		121370P01	1	1	1	
3	PUSH RETAINER		4A2414-01	3	3	3	
4	AIR FILTER (B)		121372G01	1	1	1	

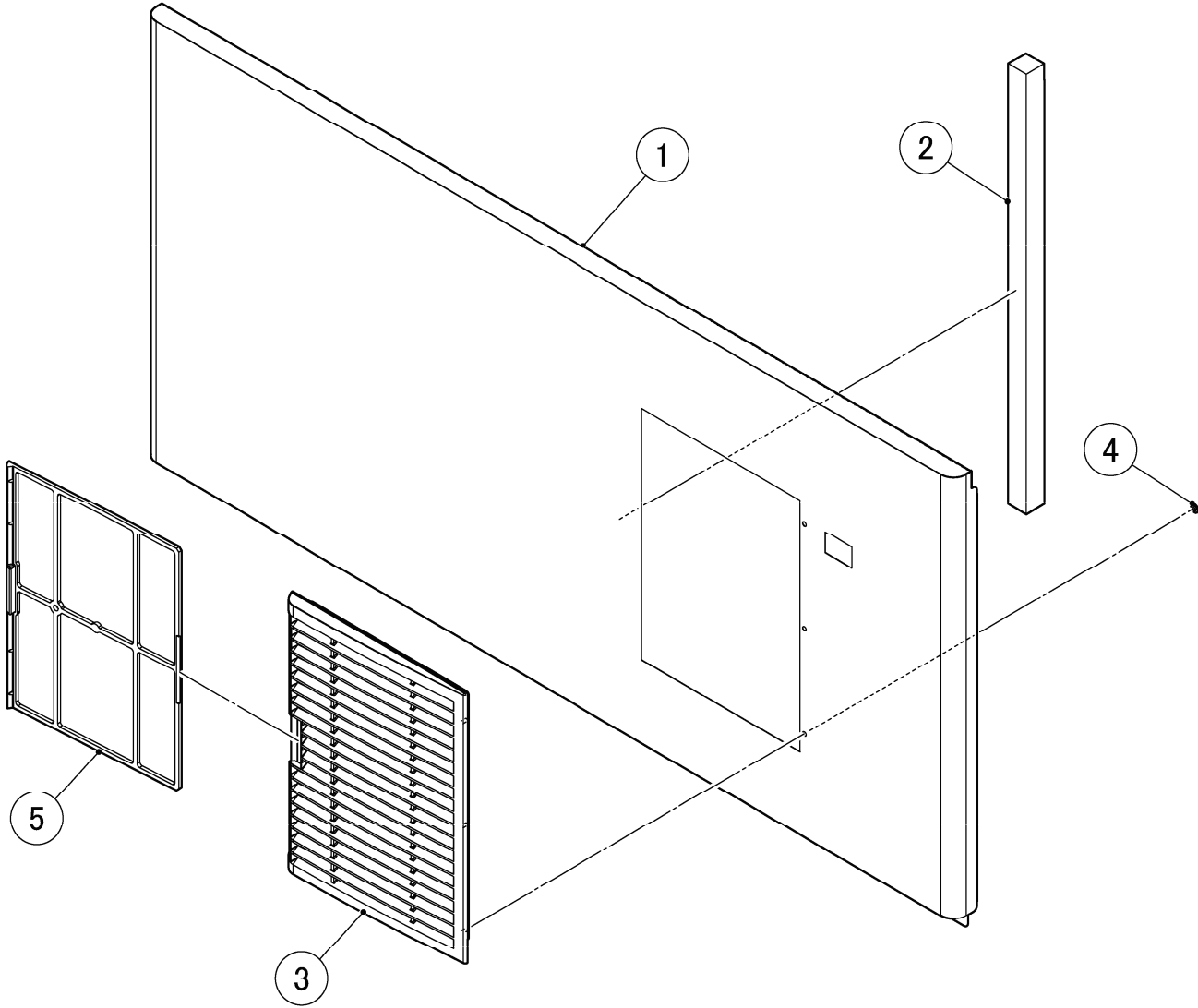

HA

MODEL: IM-500SAA		TITLE: H. FRONT COVER					
INDEX NO.	DESCRIPTION	MATERIAL OR MODEL NUMBER	PART NUMBER	REQ'D NUMBER			
				B-1	B-2 C-0	C-1	
1	FRONT COVER(A1)		121763M01	1	1	1	
2	INSULATION-SEPARATOR F		4Y6575P02	1	1	1	
3	LOUVER (B)		121370P01	1	1	1	
4	PUSH RETAINER		4A2414-01	3	3	3	
5	AIR FILTER (B)		121372G01	1	1	1	

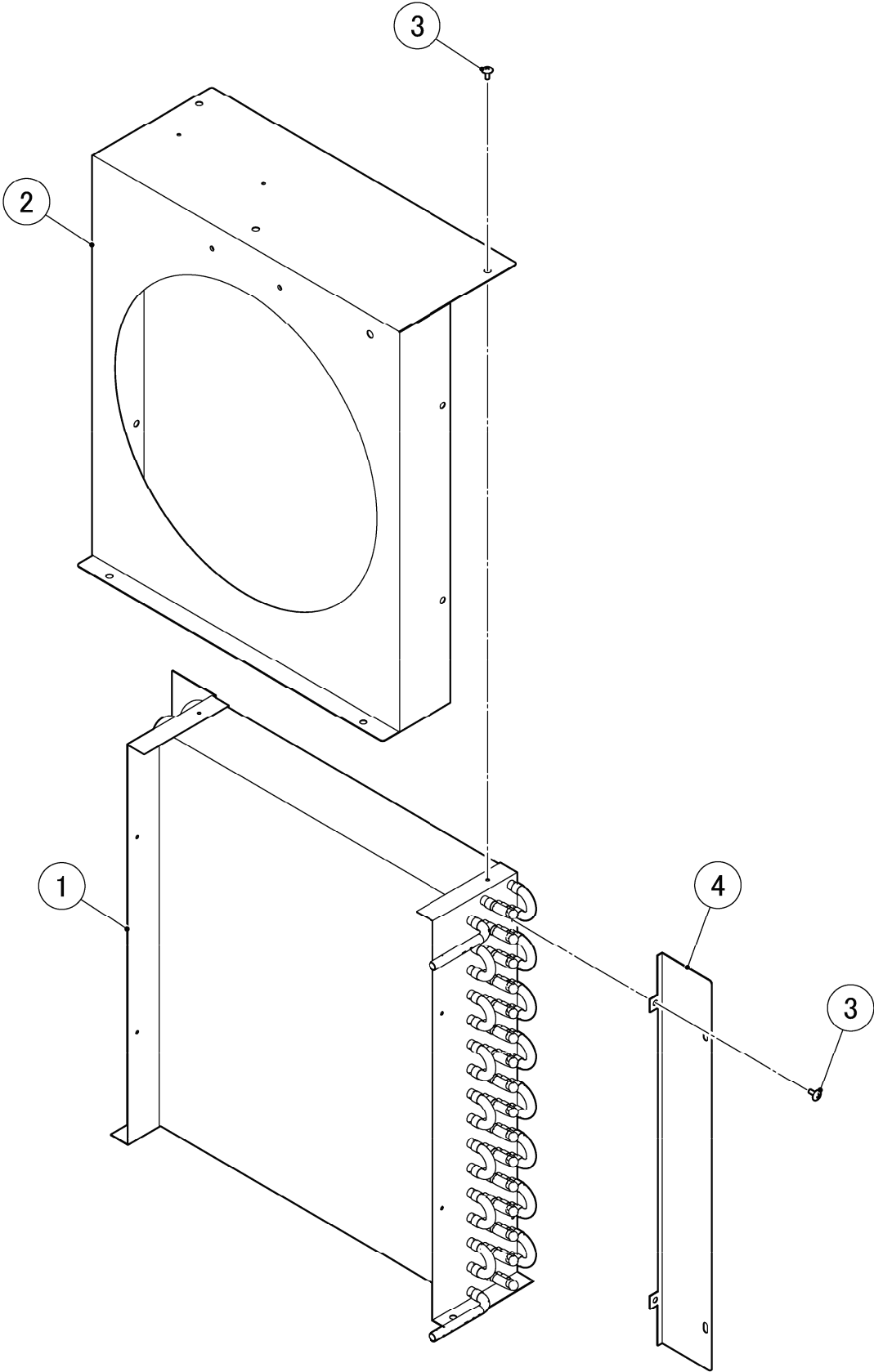

HA

MODEL: IM-500SAA		TITLE: J. COND. ASSY					
INDEX NO.	DESCRIPTION	MATERIAL OR MODEL NUMBER	PART NUMBER	REQ'D NUMBER			
				B-1	B-2 C-0	C-1	
1	CONDENSER		P03406-01	1	1	1	
2	SHROUD		261513M01	1	1	1	
3	T2 TRUSS HEAD SCREW		FT20408F0	8	8	8	
4	BRACKET-BRACKET		376259M01	1	1	1	

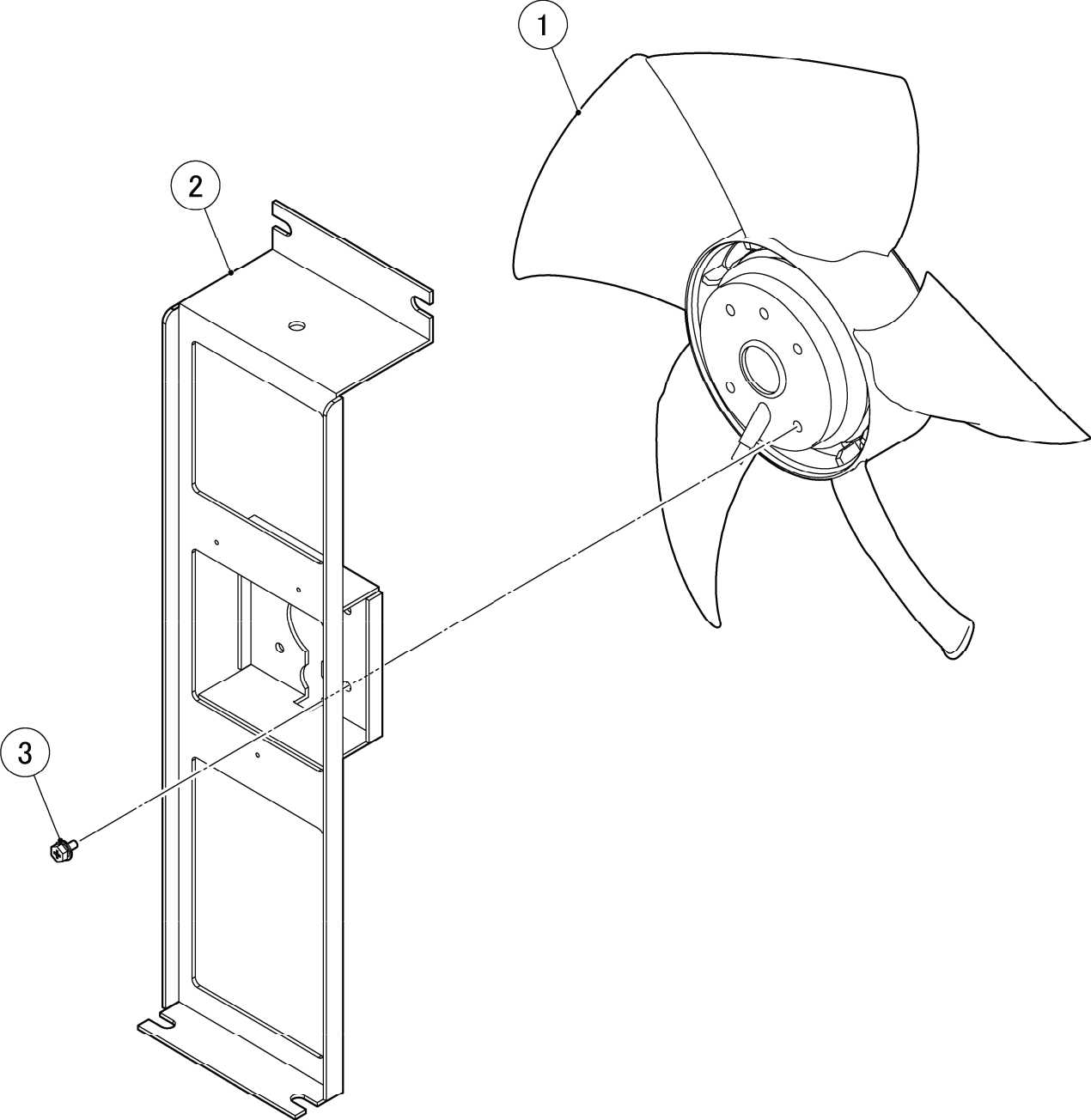

HA

MODEL: IM-500SAA		TITLE: K. FAN MOTOR ASSY					
INDEX NO.	DESCRIPTION	MATERIAL OR MODEL NUMBER	PART NUMBER	REQ'D NUMBER			
				B-1	B-2 C-0	C-1	
1	FAN MOTOR	A4E300-AU26-07	P02596-01	1	1	1	
2	FAN MOTOR BRACKET		375982G01	1	1	1	
3	HEX HEAD BOLT (SPRING WASHER AND FLAT WASHER)		FBK0408F0	3	3	3	

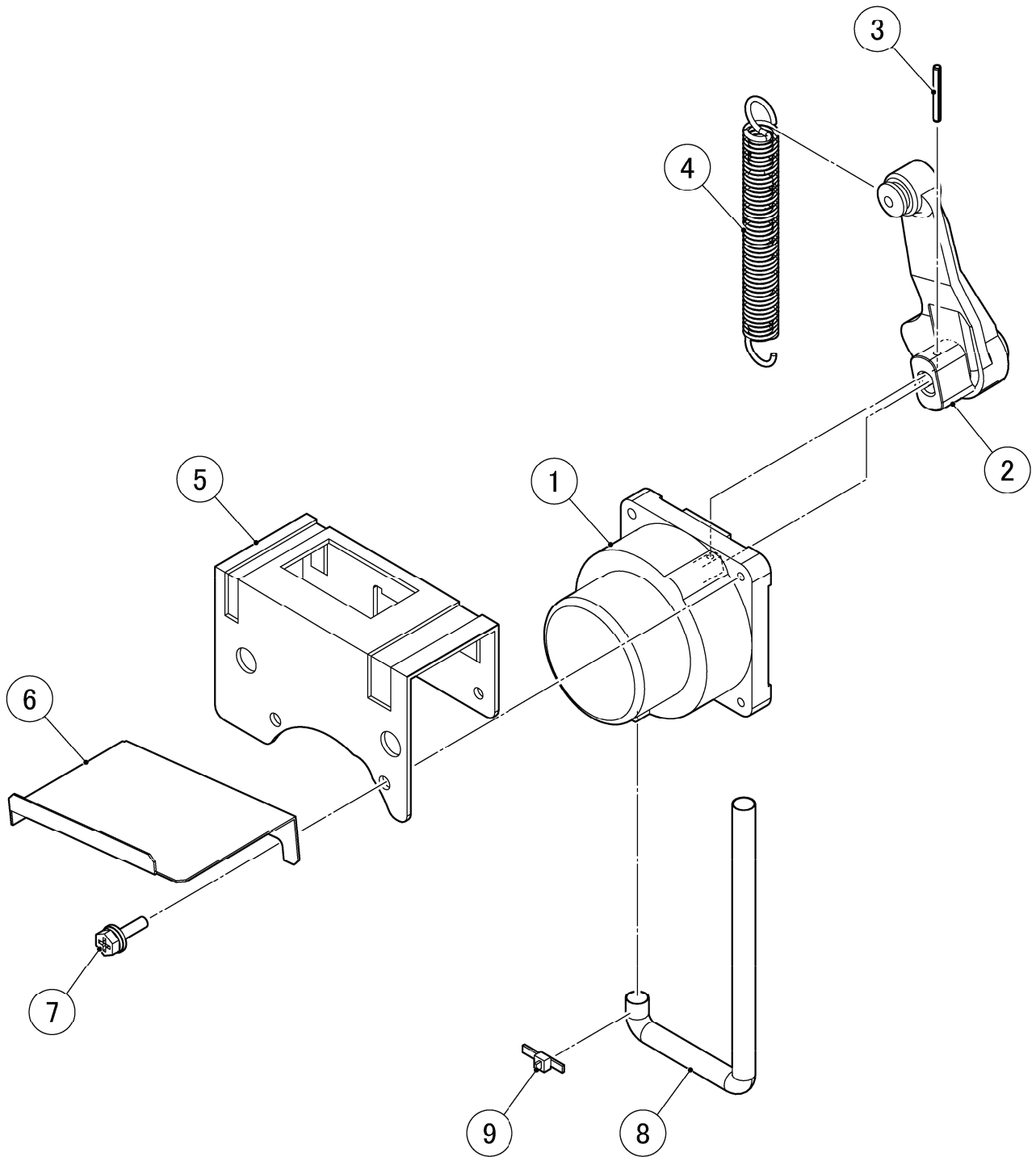

HA

MODEL: IM-500SAA				TITLE: L. ACTUATOR MOTOR ASSY			
INDEX NO.	DESCRIPTION	MATERIAL OR MODEL NUMBER	PART NUMBER	REQ'D NUMBER			
				B-1	B-2 C-0	C-1	
1	ACTUATOR MOTOR	SR555A43-23	P02382-01	1	1	1	
2	CAM(A)		306543G03	1	1	1	
3	SPRING PIN		712S-0328	1	1	1	
4	SPRING		4H3473-01	1	1	1	
5	BRACKET-AM		3Y2924M01	1	1	1	
6	BARIER-AM		476684M01	1	1	1	
7	HEX HEAD BOLT (SPRING WASHER AND FLAT WASHER)		FBK0620S0	2	2	2	
8	TUBE-UL		476686Z02	1	1	1	
9	TIE	CV-150	7920-0003	1	1	1	

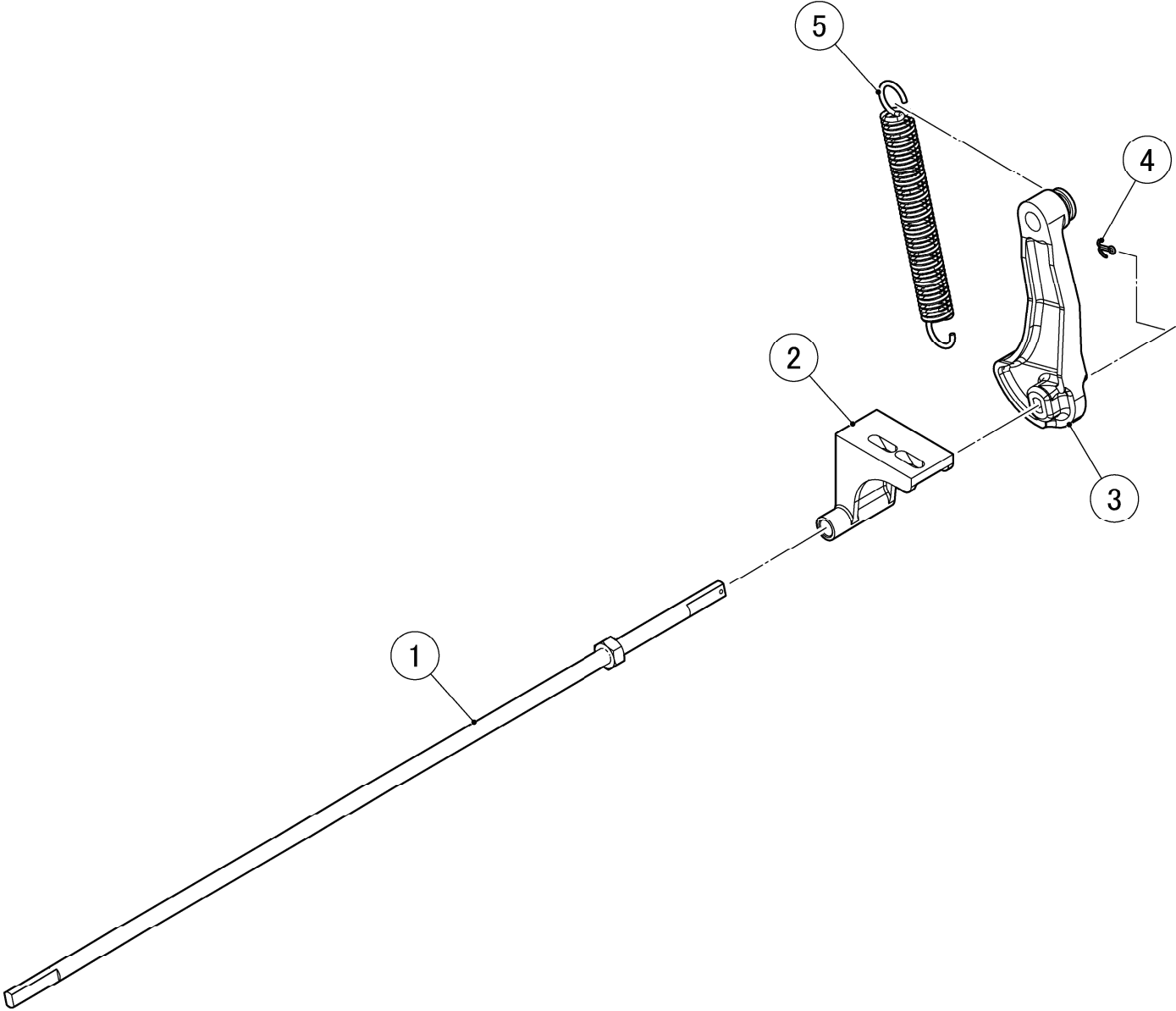

HA

MODEL: IM-500SAA		TITLE: M. CAM SHAFT ASSY					
INDEX NO.	DESCRIPTION	MATERIAL OR MODEL NUMBER	PART NUMBER	REQ'D NUMBER			
				B-1	B-2 C-0	C-1	
1	CAM SHAFT		425511G01	1	1	1	
2	BEARING-CAM SHAFT		3X8307-02	1	1	1	
3	CAM(B)		376546P01	1	1	1	
4	SPLIT PIN		711S-0212	1	1	1	
5	SPRING		4H3473-01	1	1	1	

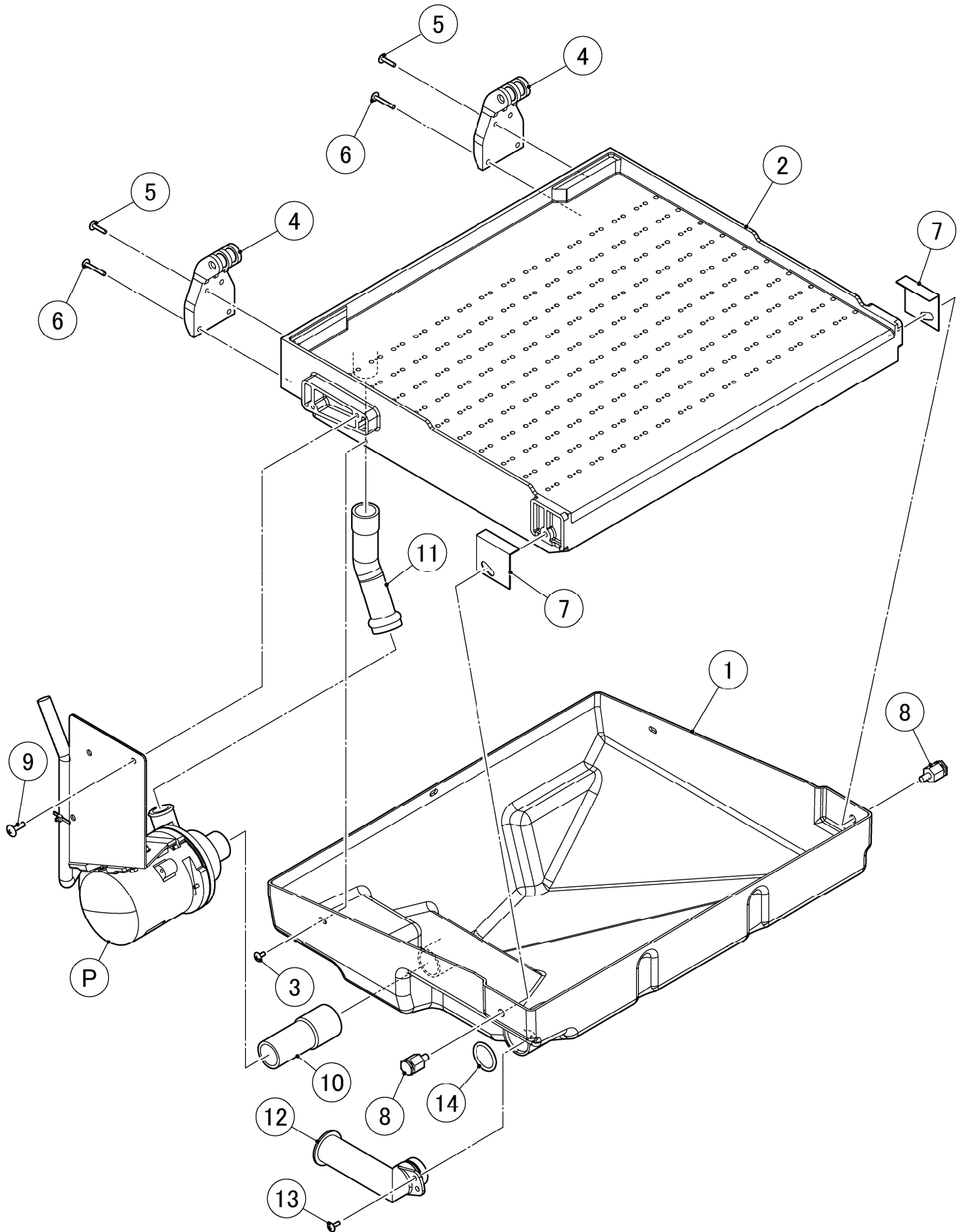

HA

MODEL: IM-500SAA		TITLE: N. WATER PAN ASSY					
INDEX NO.	DESCRIPTION	MATERIAL OR MODEL NUMBER	PART NUMBER	REQ'D NUMBER			
				B-1	B-2 C-0	C-1	
P	PUMP MOTOR ASSY		376010A01	1	1	1	
1	WATER PAN		1H0888-02	1	1	1	
2	WATER PLATE		208020G01	1	1	1	
3	T2 TRUSS HEAD SCREW		FT20408M0	3	3	3	
4	WATER PAN HANGER		3H2059-01	2	2	2	
5	T2 TRUSS HEAD SCREW		FT20416M0	4	4	4	
6	T2 TRUSS HEAD SCREW		FT20425M0	4	4	4	
7	BRACKET		402957-01	2	2	2	
8	SCREW SPRING HOOK		4H2582G01	2	2	2	
9	TRUSS HEAD TAPPING SCREW T2		FT20516M0	2	2	2	
10	SUCTION TUBE		4Y6641R01	1	1	1	
11	DISCHARGE TUBE		4Y6642R01	1	1	1	
12	PIPE-DRAIN		315530-01	1	1	1	
13	TRUSS HEAD SCREW		FST0410S0	1	1	1	
14	O-RING		7611-G025	1	1	1	

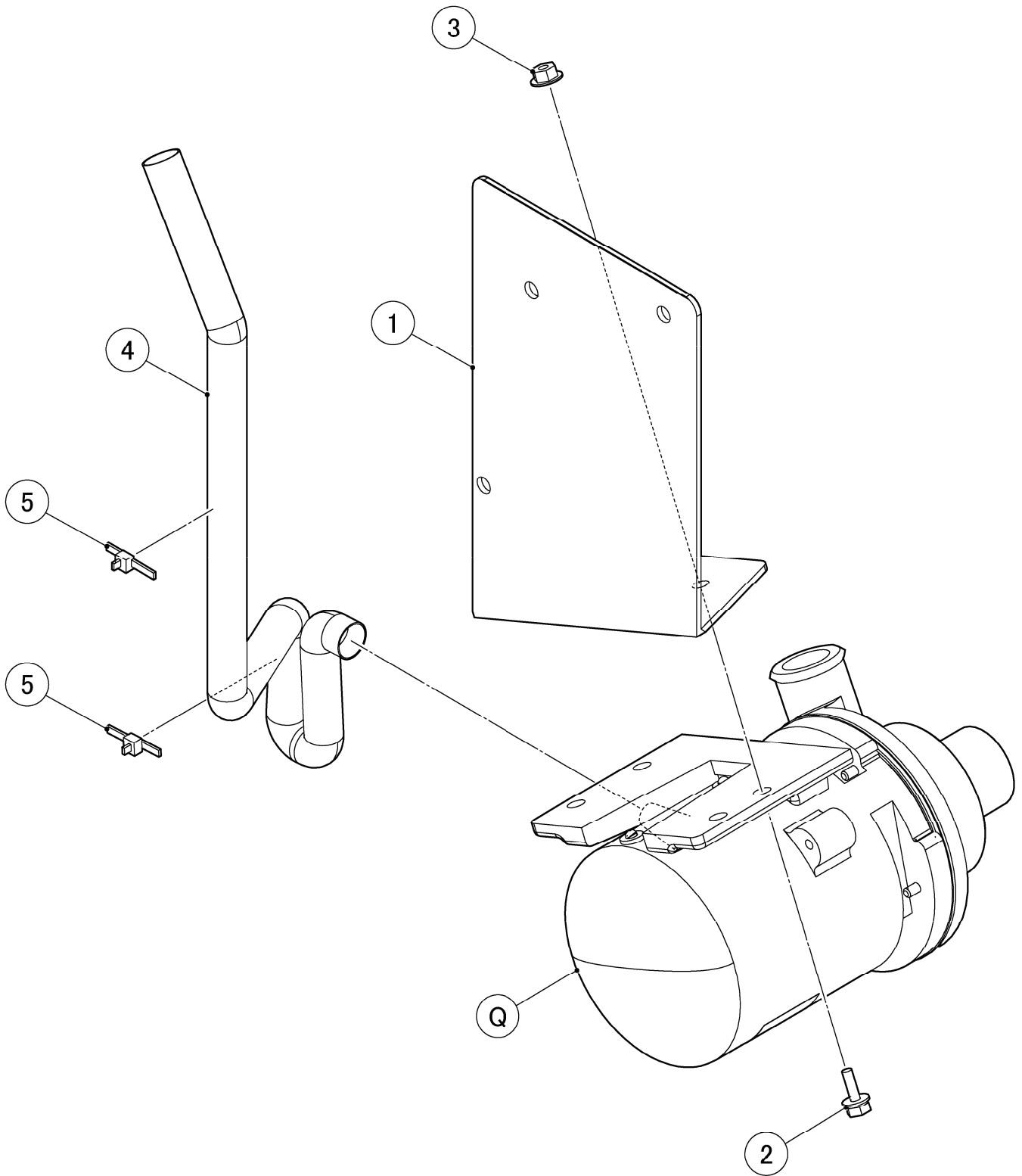

HA

MODEL: IM-500SAA				TITLE: P. PUMP MOTOR ASSY			
INDEX NO.	DESCRIPTION	MATERIAL OR MODEL NUMBER	PART NUMBER	REQ'D NUMBER			
				B-1	B-2 C-0	C-1	
Q	PUMP MOTOR		261541A01	1	1	1	
1	BRACKET-PUMP		377386M01	1	1	1	
2	HEX HEAD BOLT (SPRING WASHER AND FLAT WASHER)		FBK0412S0	4	4	4	
3	FLANGE NUT		FNHF04S0	4	4	4	
4	TUBE-UL		476686Z01	1	1	1	
5	TIE	CV-100	7920-0002	2	2	2	

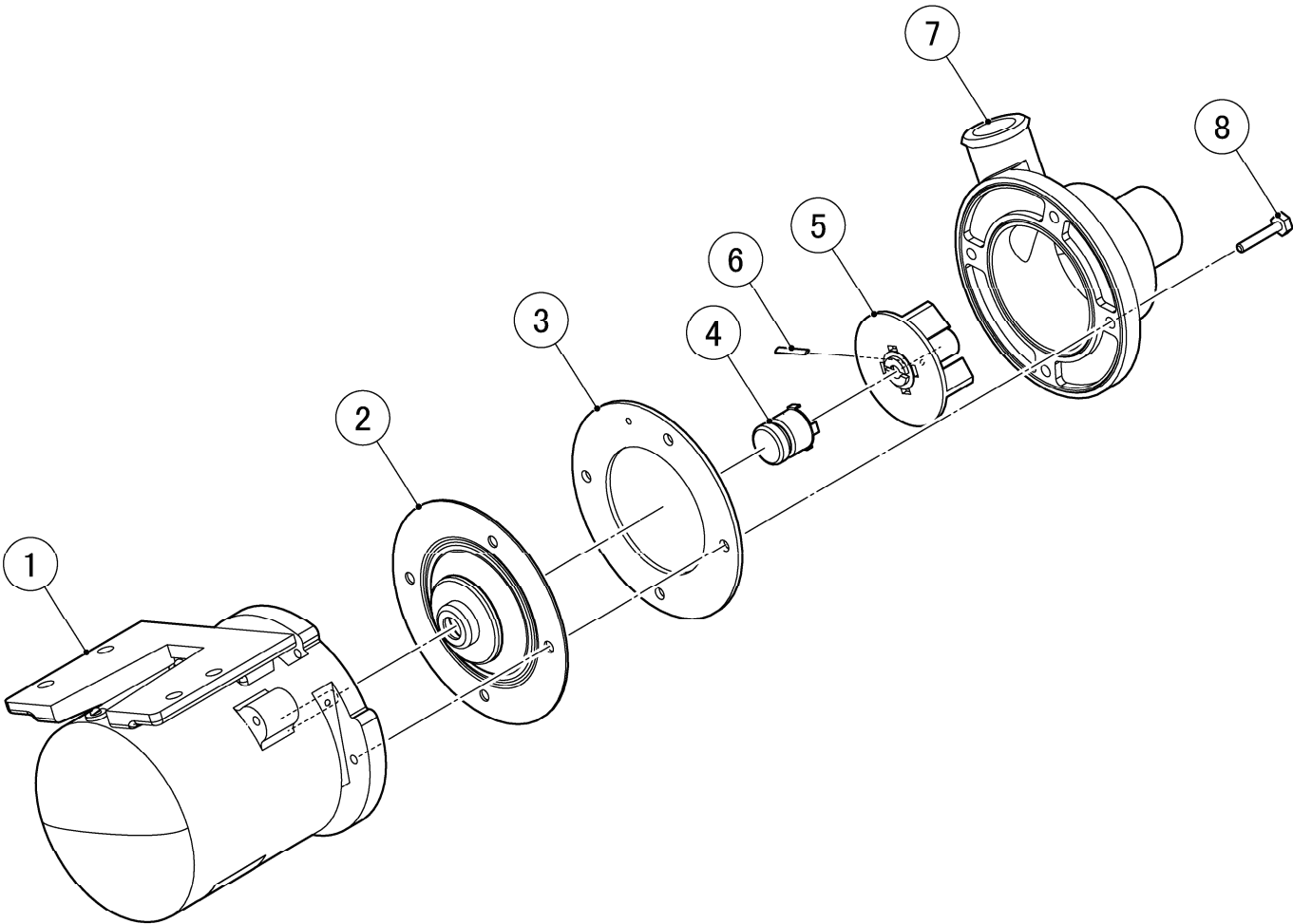

HA

MODEL: IM-500SAA		TITLE: Q. PUMP MOTOR					
INDEX NO.	DESCRIPTION	MATERIAL OR MODEL NUMBER	PART NUMBER	REQ'D NUMBER			
				B-1	B-2 C-0	C-1	
1	PUMP MOTOR		2A2758-01	1	1	1	
2	PUMP FLANGE		3A2988-01	1	1	1	
3	PUMP GASKET		4A2974-01	1	1	1	
4	MECHANICAL SEAL		465627-01	1	1	1	
5	IMPELLER		433522-01	1	1	1	
6	SCREW RETAINING PIN		414102-01	1	1	1	
7	PUMP HOUSING		261284P01	1	1	1	
8	SCREW		4A3871-01	4	4	4	

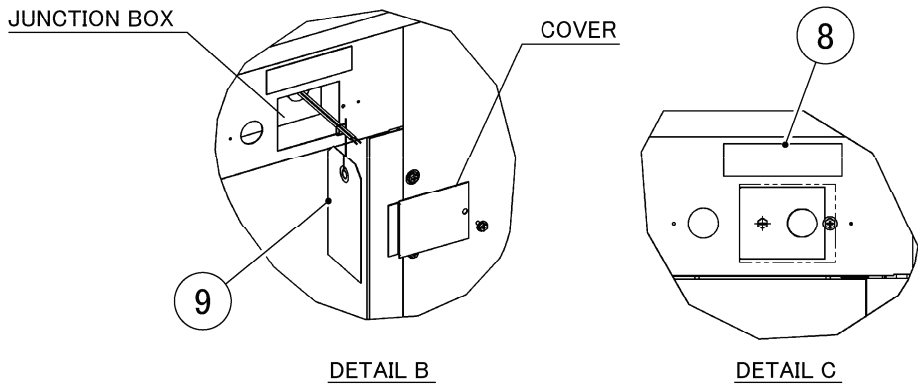
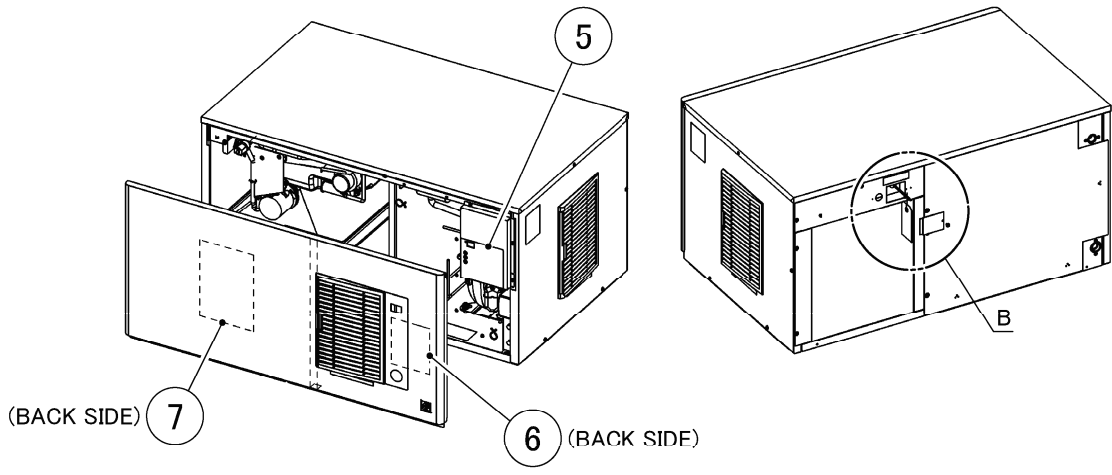
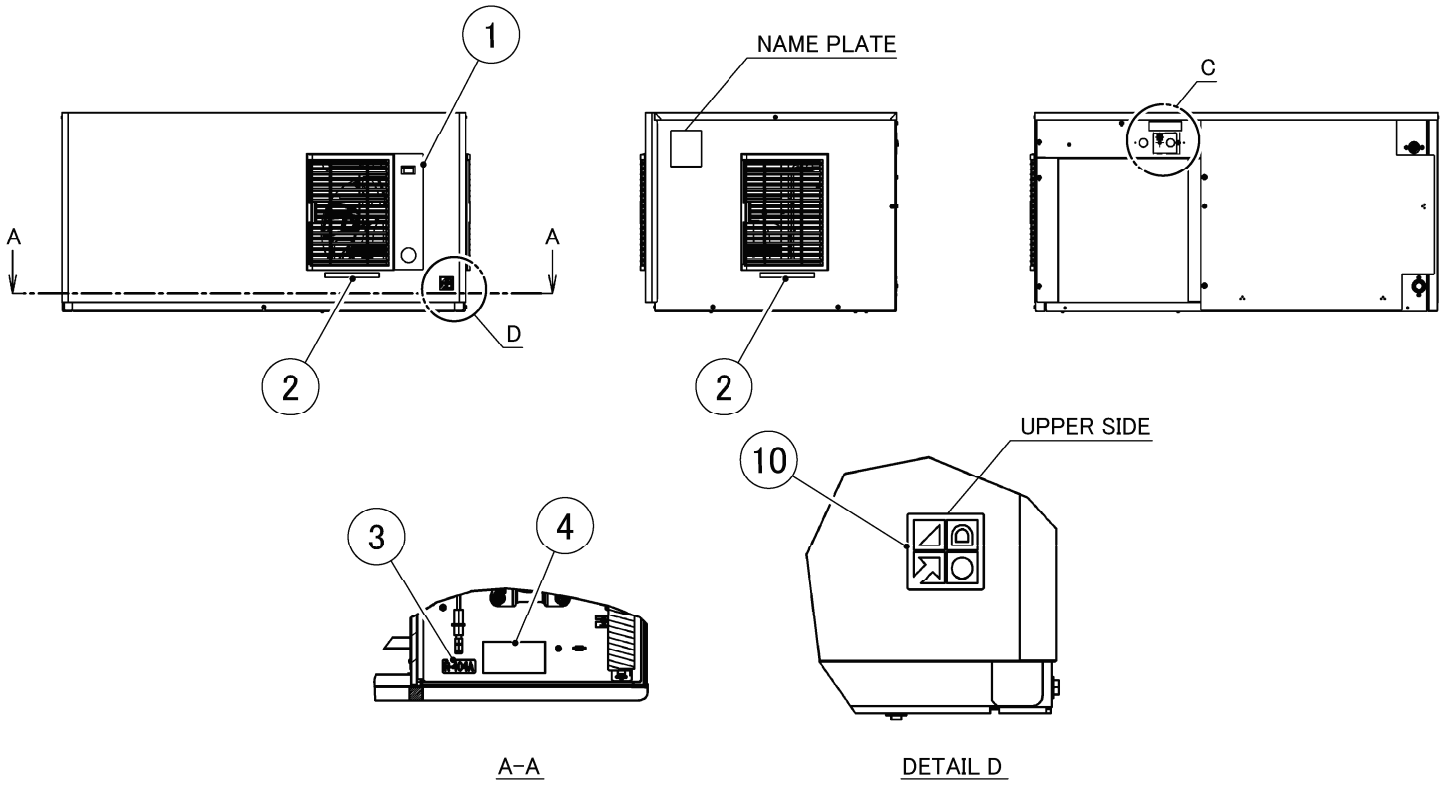

HA

MODEL: IM-500SAA		TITLE: S. LABEL LOCATION					
INDEX NO.	DESCRIPTION	MATERIAL OR MODEL NUMBER	PART NUMBER	REQ'D NUMBER			
				B-1	B-2 C-0	C-1	
1	OPERATION LABEL		376391L01	1	1	1	
2	LABEL - AIR FILTER		426177-01	2	2	2	
3	LABEL/R-404A		453230-01	1	1	1	
4	CAUTION LABEL - SERVICE		370640L01	1	1	1	
5	CONTROL LABEL		376390L01	1	1	1	
6	WIRING LABEL		376066L01	1	1	1	
7	MAINTENANCE LABEL		261632L01	1	1	1	
8	ELECTRICAL LABEL		377100L01	1	1	1	
9	TAG - WARNING ELECT CONNECTION		4A4766-01	1	1	1	
10	LABEL - HACCP		476519L01	1	1	1	

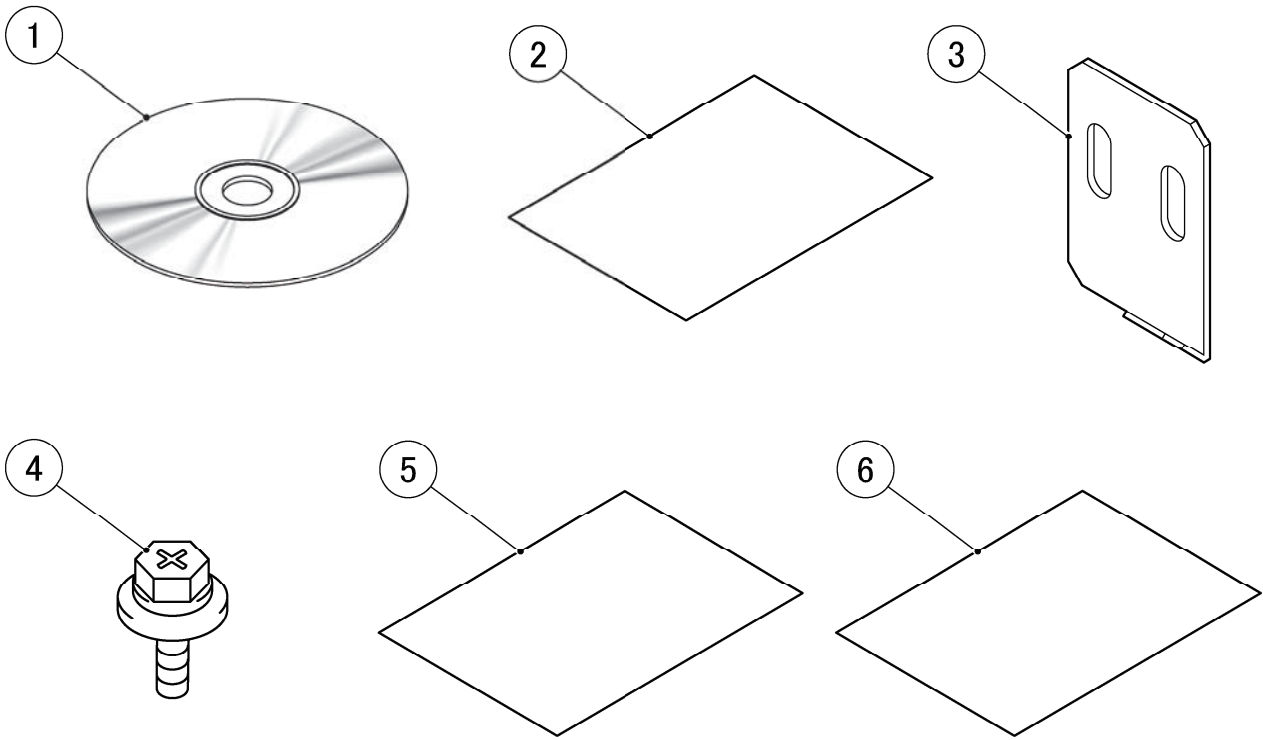

HA

MODEL: IM-500SAA		TITLE: T. ACCESSORIES					
INDEX NO.	DESCRIPTION	MATERIAL OR MODEL NUMBER	PART NUMBER	REQ'D NUMBER			
				B-1	B-2 C-0	C-1	
1	INSTRUCTION MANUAL		L1M029101	1	1	1	
2	REGISTRATION CARD		2A2894-01	1	1	1	
3	BRACE		4Y5926M01	2	2	2	
4	HEX HEAD BOLT (SPRING WASHER AND FLAT WASHER)		FBK0512S0	2	2	2	
5	INSTRUCTION SHEET		261630L01	1	1	1	
6	CERTIFICATE-WARRANTY		263553L01	1	1	1	