

KMD-410M_H

MODULAR CRESCENT CUBER

Item # _____

Project: _____

Qty: _____

*AutoCad available on KCL

KMD-410M_H

11/09

Item # 13247

CUBER DIMENSIONS

W x D x H

KMD-410M_H
22 x 24 x 24





KMD-410MAH

Air-Cooled
Shown on an optional
Lancer 22" Dispenser

KMD-410MWH

Water-Cooled

- Up to 440 lbs. of ice production per 24 hours
- Ice on beverage design
- Durable stainless steel exterior
- Individual crescent cube
- CycleSaver® Design 
- EverCheck® alert system 
- Stainless steel evaporator
- Removable air filters (Air-cooled model only)
- Complies with California Energy Commission guidelines (CEC)
- R-404A Refrigerant

* The KMD-410MAH is ENERGY STAR certified.



Warranty

Valid in United States, Canada, Puerto Rico, & U.S. Territories. Contact factory for warranty in other countries.

Three Year - Parts & Labor on entire machine.

Five Year - Parts & Labor on: Evaporator.

Five Year - Parts on: Compressor, air-cooled condenser coil.



Hoshizaki

KMD-410M_H MODULAR CRESCENT CUBER

DIMENSIONS
W x D x H
KMD-410M_H
22 x 24 x 24

- Air-cooled
- Water-cooled

AIR-COOLED

Water Temp° F.	50°	70°	90°
Air Temp° F.	70°	415	388
	80°	395	353
	90°	388	324

WATER-COOLED

Water Temp° F.	50°	70°	90°
Air Temp° F.	70°	440	423
	80°	427	401
	90°	423	382

UTILITY CONSUMPTION

Model Number	Ice Production Per Cycle		KWH per 100 LBS. 90/70	Potable Water Gal. per 100 lbs. 90/70	Condenser Water Gal. per 100 lbs. 90/70
	Lbs.	Cubes			
KMD-410MAH	8.5	416	5.8	22.6	N/A
KMD-410MWH	8.2	416	4.3	23.2	145

SPECIFICATIONS

Model Number	Condenser	Amperage	Min. Circuit Ampacity	Shipping Weight
KMD-410MAH	Air-Cooled	8.0	15	161 lbs.
KMD-410MWH	Water-Cooled	6.5	15	163 lbs.

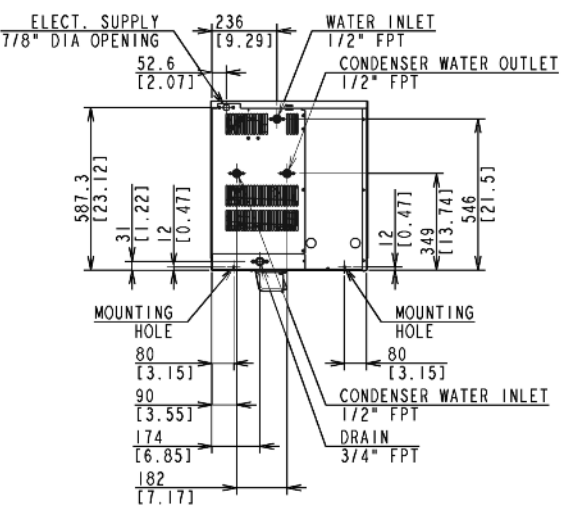
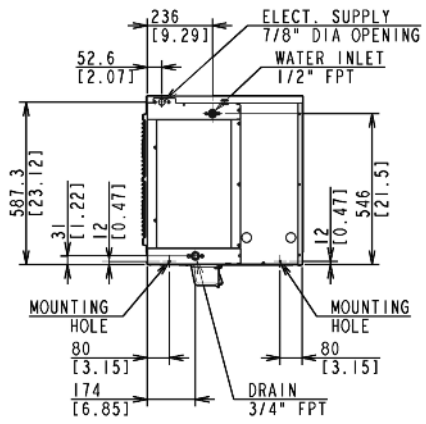
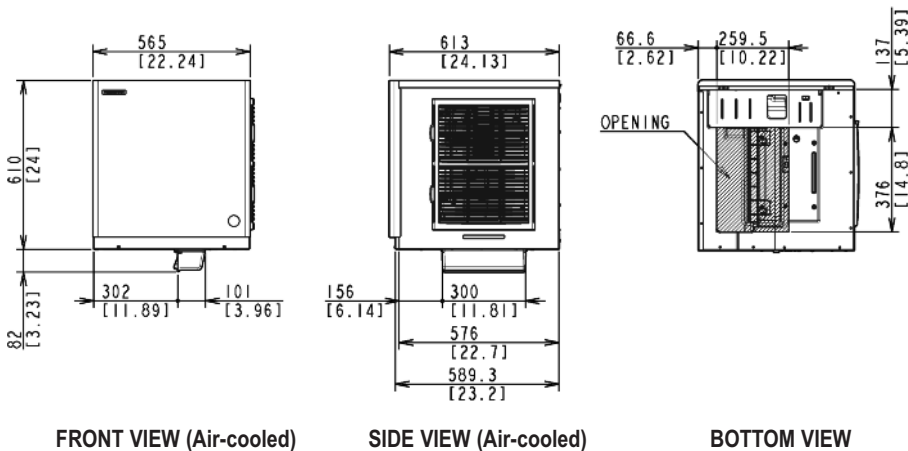

ELECTRICAL & PLUMBING/KMD-410M_H

- 115/60/1
- 15 amp Max Fuse/HACR Breaker Size
- 3/8" OD copper or equivalent independent potable water supply
- 3/4" FPT independent drain connection

OPERATING LIMITS

- Ambient Temp Range 45 - 100°F
- Water Temp Range 45 - 90°F
- Water Pressure 10 - 113psig
- Voltage Range 104 - 127V

SERVICE

- Panels easily removed and all components accessible for service.
- Removable/cleanable air filters. (Air-Cooled model only)



© HOSHIZAKI AMERICA, INC.

618 Hwy. 74 S., Peachtree City, GA 30269

TEL 1-800-438-6087

FAX 1-800-345-1325

www.hoshizaki.com

Printed in U.S.A.

